

Ultra High Purity Immersible Thermal Gas Mass Flow Meter

Features

- The ultra high purity meters are constructed of 316L electro-polished stainless-steel with a 7 to 10 Ra interior finish
- Measures mass flow directly, no separate temperature or pressure inputs required
- Built-in flow conditioner which eliminates velocity-profile distortions caused by upstream disturbances
- Field adjustment of critical flow meter settings via on-board switches or Smart Interface™ (RS-232)
- Field validation of flow meter calibration
- Outstanding rangeability
- One-second response to changes in flow rate
- FM, CSA and ATEX certified for hazardous areas
- CE approved
- PED available

SIERRA[®]
INSTRUMENTS
THE MASS FLOW COMPANY



For information online...

www.sierrainstruments.com

Ultra High Purity Model 780S



Description

Sierra Instruments' ultra high purity (UHP) model 780S immersible thermal gas mass flow meters are the instruments of choice for gas distribution service in semiconductor fabs, pharmaceutical production and other ultra-clean processes. UHP meters are constructed of 316L electro-polished stainless-steel with a 7 to 10 Ra interior finish.

The versatile microprocessor-based transmitter integrates the functions of flow-range adjustment, meter validation and diagnostics in either a probe-mounted or remote housing. Mass flow rate and totalized flow, as well as other configuration variables, are displayed on the optional 2 x 12 LCD display. The programmable transmitter is easily configured via an RS-232 communication port and Sierra's Smart Interface™ software, or via the display and magnetic switches on the instruments display.

The model 780S smart electronics allow you to easily configure the following performance parameters: flow range, reset totalizer, alarm settings, time response, low flow cut-off and a calibration correction factor. The Smart Interface™ also allows for field validation of flow meter performance and calibration.

The model 780S has a built-in flow conditioning which eliminates velocity-profile distortions caused by upstream disturbances.

The meter is FM, CSA, ATEX and PED approved for operation in hazardous areas and is available with a variety of input power, output signal, mounting and packaging options.

Dimensional Specifications

1 Through 6-inch 780S UHP (E2)

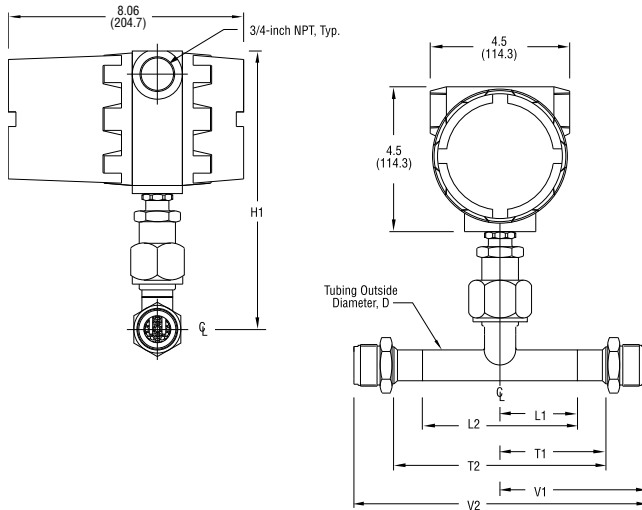

780S UHP DIMENSIONS

TUBING SIZE	GENERAL		BUTT WELD		TRI-CLAMP		VCR		TUBE WALL
	H1	H2	L1	L2	T1	T2	V1	V2	
.375 (9.5)	10.30 (262)	10.20 (259)	2.85 (72.4)	5.70 (144.8)	—	—	3.48 (88.4)	6.96 (176.8)	.035 (0.9)
.500 (12.7)	10.40 (264)	10.20 (259)	2.90 (73.7)	5.80 (147.3)	—	—	4.00 (101.6)	8.00 (203.2)	.049 (1.2)
1.00 (25.4)	9.10 (231.1)	9.20 (234)	2.50 (63.5)	5.00 (127)	3.00 (76.2)	6.00 (152.4)	4.72 (119.9)	9.44 (239.8)	.065 (1.7)
1.50 (38.1)	9.10 (231.1)	9.30 (231.3)	2.00 (50.8)	5.50 (139.7)	2.50 (63.5)	6.50 (165.1)	—	—	.065 (1.7)
2.00 (50.8)	10.90 (276.9)	10.80 (276.9)	2.50 (63.5)	7.00 (177.8)	3.00 (76.2)	8.00 (203.2)	—	—	.065 (1.7)
3.00 (76.2)	10.70 (271.8)	10.90 (276.9)	3.00 (76.2)	10.50 (266.7)	3.50 (88.9)	11.50 (292.1)	—	—	.065 (1.7)
4.00 (101.6)	10.70 (271.8)	10.90 (277)	4.00 (101.6)	14.00 (355.6)	4.62 (116.8)	15.25 (387.4)	—	—	.083 (2.1)
6.00 (152.4)	12.70 (322.6)	11.90 (302)	6.00 (152.4)	21.00 (533.4)	—	—	—	—	.109 (2.8)

UP STREAM STRAIGHT PIPE LENGTH REQUIREMENTS⁽¹⁾ AT 1 ATM

Piping Condition	3/8 and 1/2-inch 780SUHP ⁽²⁾	1 to 6-inch 780SUHP ⁽⁴⁾
Single 90° Elbow or T-Piece	1D	1D
Reduction (4:1)	1D	3D
Expansion (4:1)	3D	3D
After Control Valve	3D	3D
Two 90° Elbows (In Same Plane)	3D	3D
Two 90° Elbows (Different Planes)	5D	5D

- Notes: (1) Number of diameters (D) of straight pipe required between upstream disturbance and the flow meter.
 (2) Requires 1D of straight pipe downstream of the flow meter.
 (3) Requires 3D of straight pipe downstream of the flow meter.
 (4) Requires 0D of straight pipe downstream of the flow meter.
 (5) Consult factory for pressure effect.

All dimensions are in inches. Millimeters are in parentheses. Certified drawings are available on request.

Remote 780S UHP Specifications

Remote Mounted with Junction Box (E4)

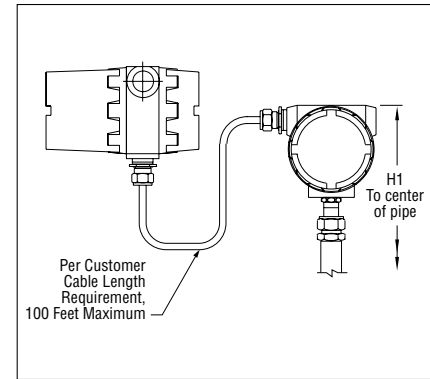

NEMA 4X Remote Mounted with Junction Box (EN4)

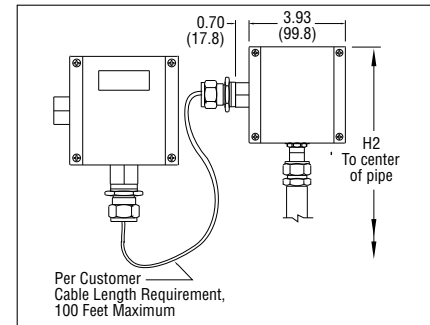

3/8 & 1/2-inch 780S UHP—Side View (EN2)

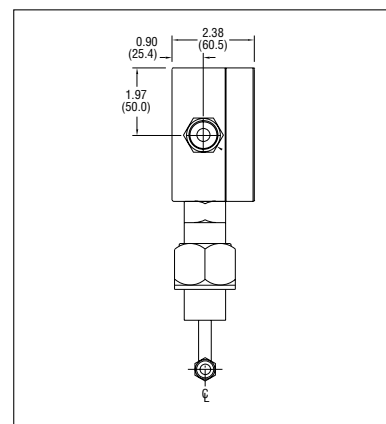

3/8 & 1/2-inch 780S UHP—Front View (EN2)

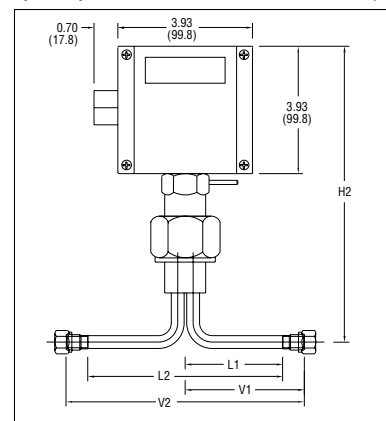

Performance Specifications

Accuracy

+/- 1% of reading + 0.5 % of full scale

Repeatability

+/- 0.2% of full scale

Temperature Coefficient

+/- 0.02% of reading per °F within +/- 50° F of customer specified conditions

+/- 0.03% of reading per °F within +/- 50° F to 100° F of customer specified conditions

+/- 0.04% of reading per °C within +/- 25° C of customer specified conditions

+/- 0.06% of reading per °C within +/- 25° C to 50° C of customer specified conditions

Pressure Coefficient

.02% per psi for air, consult factory for other gases

Response Time

One second to 63% of final velocity value

Operating Specifications

Gases

Argon, helium, hydrogen, nitrogen, oxygen (consult factory for other gases)

Gas Pressure

Mechanical design pressure:

Compression fittings: 500 psig (34.5 barg)

Gas & Ambient Temperature

Gas -40° F to 250° F (-40° C to 120° C)

Ambient -40° F to 120° F (-40° C to 50° C)

Leak Integrity

5 X 10⁻⁹ cc/sec of helium maximum

Power Requirements

18 to 30 VDC (regulated), 625 mA maximum

100 to 240 VAC, 50/60 Hz, 15 watts maximum

Output Signal

Linear 0–5 VDC or 0-10 VDC proportional to mass flow rate,
1000 ohms minimum load resistance or

Linear 4–20 mA proportional to mass flow rate,
700 ohms maximum resistance power supply dependent
User-selectable. Active non-galvanically separated or
passive galvanically separated (loop powered)

Alarms

Hard contact user-adjustable high and low

Dead band adjustable with Smart Interface™ software

Relay ratings: Maximum 400 VDC or VAC (peak), 140 mA

Displays

Alphanumeric 2 x 12 digit backlit LCD

Adjustable variables via on-board switches (password protected)
or with Smart Interface™ software

Adjustable variable; Full scale (50 to 100 %)

Time Response (1 to 7 seconds)

Correction factor setting (0.5 to 5)

Zero and span

Totalizer

Seven digits (9,999,999) in engineering units

Resettable by software, on-board switches or external magnet

Software

Smart Interface™ Windows®-based software

Minimum 8 MB of RAM, preferred 16 MB of RAM

RS-232 communication

Additional features: Alarm dead band adjustment

Zero cut-off adjustment

Linearization adjustment

Save / Load configurations

Flow meter validation

Physical Specifications

Wetted Materials

316L stainless steel

UHP: 7 to 10 Ra internal finish

Enclosure

Hazardous-Area location enclosure (IP66) or NEMA 4X (IP65)

Both are powder-coated cast aluminum

Electrical Connection

Two 3/4 inch NPT . . . Hazardous-Area location enclosure (IP66)

One 1/2 inch NPT . . . NEMA 4X Enclosure (IP65)

Certifications

CE (All enclosures)

CSA (Explosion proof for Class I, Division 1, Groups B, C, D)

ATEX (II 2 GD Ex d IIC T6 ... T2; IP 66 ... T70 °C ... T280 °C)

FM (Explosion proof for Class I, Division 1, Groups B, C, D; dust-ignition proof for Class II, III, Division 1, Groups E, F, G)

IP65, NEMA 4X T6 -40° C to 70° C ambient

PED optional

Pressure Drop

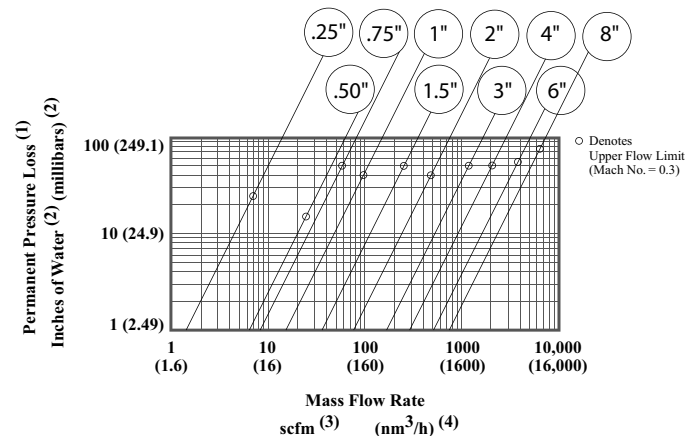

Notes:

(1) For air and nitrogen at 20 °C temperature and 1 atmosphere pressure.

(2) 1 inch of water at 60 °F = 0.0361 psi.

1 millibar = 0.001 bar = 100 pascal = 0.0145 psi.

(3) At base conditions of 21.1 °C temperature and 1 atmosphere pressure.

(4) At base conditions of 0 °C temperature and 1 atmosphere pressure.

(5) Built-in flow conditioner consists of two separate perforated plates in series.

Ordering the Model 780S UHP

