

Low-Cost Mass Flow Controllers for Gas with Digital Display

Features

- All the performance features of a standard MFC at an affordable price!
- On-board display and local set point control eliminates need for external electronics
- Switch-selectable remote set point interfaces easily with PLC or workstation
- Large, straight sensor tube reduces contamination and maintenance down-time
- Platinum sensor eliminates zero-drift and ensures long-term repeatability
- Fast-response control valve provides quick response to set point changes
- Primary standard calibration ensures starting point accuracy and NIST traceability
- CE Approved

SIERRA
INSTRUMENTS
THE MASS FLOW COMPANY



For information online...
www.sierrainstruments.com

Mass-Trak[®] Model 810C



Description

Sierra Instruments' Mass-Trak[®] Model 810C offers exceptional mass flow control capabilities at an attractive price. Available in any range from 0 to 10 sccm to 0 to 50 slpm, the Model 810C is suitable for any clean, non-corrosive gas flow control application.

Mass-Trak's on-board display and local set point potentiometer allows for adjustment of the command signal from the face of the instrument enclosure and eliminates the need for external readout/set point electronics.

The instrument also offers a switch-selectable remote set point capability from either a 4 to 20 mA or 0 to 5 VDC command signal, which can be easily interfaced with a process control system or workstation.

The instruments' built-in, electromagnetic, servo-control valve offers both a purge mode and a valve-close command from an external contact, a fast response to set point changes and a 0.25% repeatability specification.

Designed to reduce costs in analytical, laboratory and OEM instrument applications, Mass-Trak provides all the performance features of a standard mass flow controller at an affordable price!

Dimensional Specifications

Model 810C – Front View

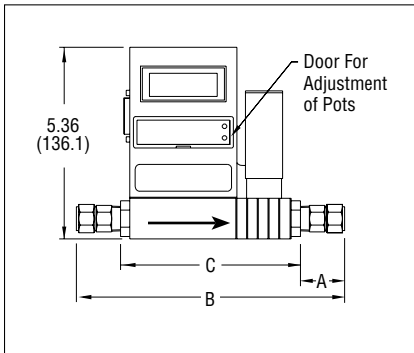

Model 810C – Outlet View

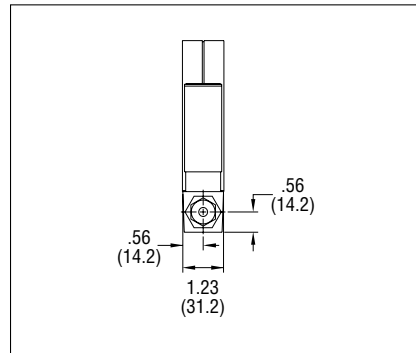

Model 810C – Bottom View

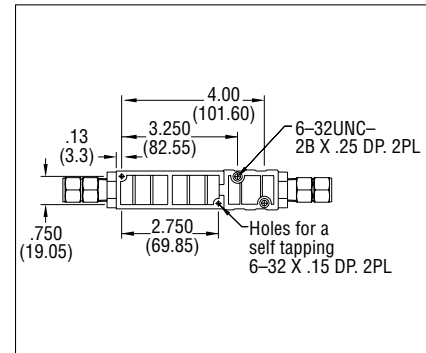

All dimensions are inches and in parentheses are millimeters. Certified drawings are available on request.

FITTING SIZE

	1/8-inch Compression	1/4-inch Compression	1/4-inch NPT
Dim. A	1.01 (25.7)	1.09 (27.7)	—
Dim. B	7.01 (178.1)	7.19 (182.6)	—
Dim. C	5.00 (127.00)	5.00 (127.00)	5.00 (127.00)

Performance Specifications

Accuracy

+/- 1.5% of Full Scale including linearity over 60° to 80°F (15° to 25°C) and 5 to 60 psia (0.3 to 4 bara) If the instrument is mounted with a vertical (up or down) flow path the following accuracy de-rating applies:

Inlet Pressure Deviation ²	OPERATING PRESSURE		
	50 psig	100 psig	150 psig
+/- 1 psig	+/- 1.5% of Full Scale	+/- 1.5% of Full Scale	+/- 1.5% of Full Scale
+/- 5 psig	+/- 3.8% of Full Scale	+/- 4.5% of Full Scale	+/- 5.3% of Full Scale
+/- 10 psig	+/- 6% of Full Scale	+/- 7.5% of Full Scale	+/- 9% of Full Scale

Notes:

(1) Do not exceed 150 psig.

(2) Difference between inlet pressure and calibrated pressure. Do not exceed +/- 10 psig.

Repeatability

+/- 0.25% of Full Scale

Temperature Coefficient

0.08% of Full Scale per °F (0.15% of Full Scale per °C), or better

Pressure Coefficient

0.01% of Full Scale per psi (0.15% of Full Scale per bar), or better

Response Time

800 ms time constant; six seconds (typical) to within +/- 2% of final value over 25 to 100% of Full Scale

Operating Specifications

Gases

Most gases (e.g., air, nitrogen, carbon dioxide, argon, methane, hydrogen, helium); check compatibility with wetted materials; specify when ordering

Mass Flow Rates

0 to 10 sccm to 0 to 50 slpm; flow ranges specified are for an equivalent flow of nitrogen at 760 mm Hg and 21°C (70°F); other ranges in other units are available (e.g., scfh or nm³/h)

Gas Pressure

150 psig (10 barg) maximum

20 psig (1.4 barg) optimum

Differential Pressure Requirement

15 to 50 psi (1.0 to 3.4 bar) optimum

Gas & Ambient Temperature

32 to 122°F (0 to 50°C)

Leak Integrity

1 X 10⁻⁴ atm cc/sec of helium maximum

Power Requirements

24 VDC +/- 10%, 350 mA, regulated

Control Range

Calibrated for 2 to 100% of Full Scale flow

Automatic shut-off at 0.5 to 3.0% of Full Scale

Output Signal

Linear 0 to 5 VDC, 2000 ohms minimum load resistance

Linear 0 to 10 VDC, 2000 ohms minimum load resistance optional

Linear 4 to 20 mA, 1000 ohms maximum loop resistance for 24 VDC supply

Command Signal

Local Potentiometer

Remote Switch selectable 0 to 5 VDC or 4 to 20 mA

Controls

Local set point potentiometer

Zero potentiometer

Valve is closed when power is off

Display

3.5 digit LCD

Physical Specifications

Wetted Material

10% glass-filled Nylon[®] 6/6; 316 stainless steel; 430F stainless steel; nickel plating; Viton[®] "O"-rings

Ordering the Model 810C

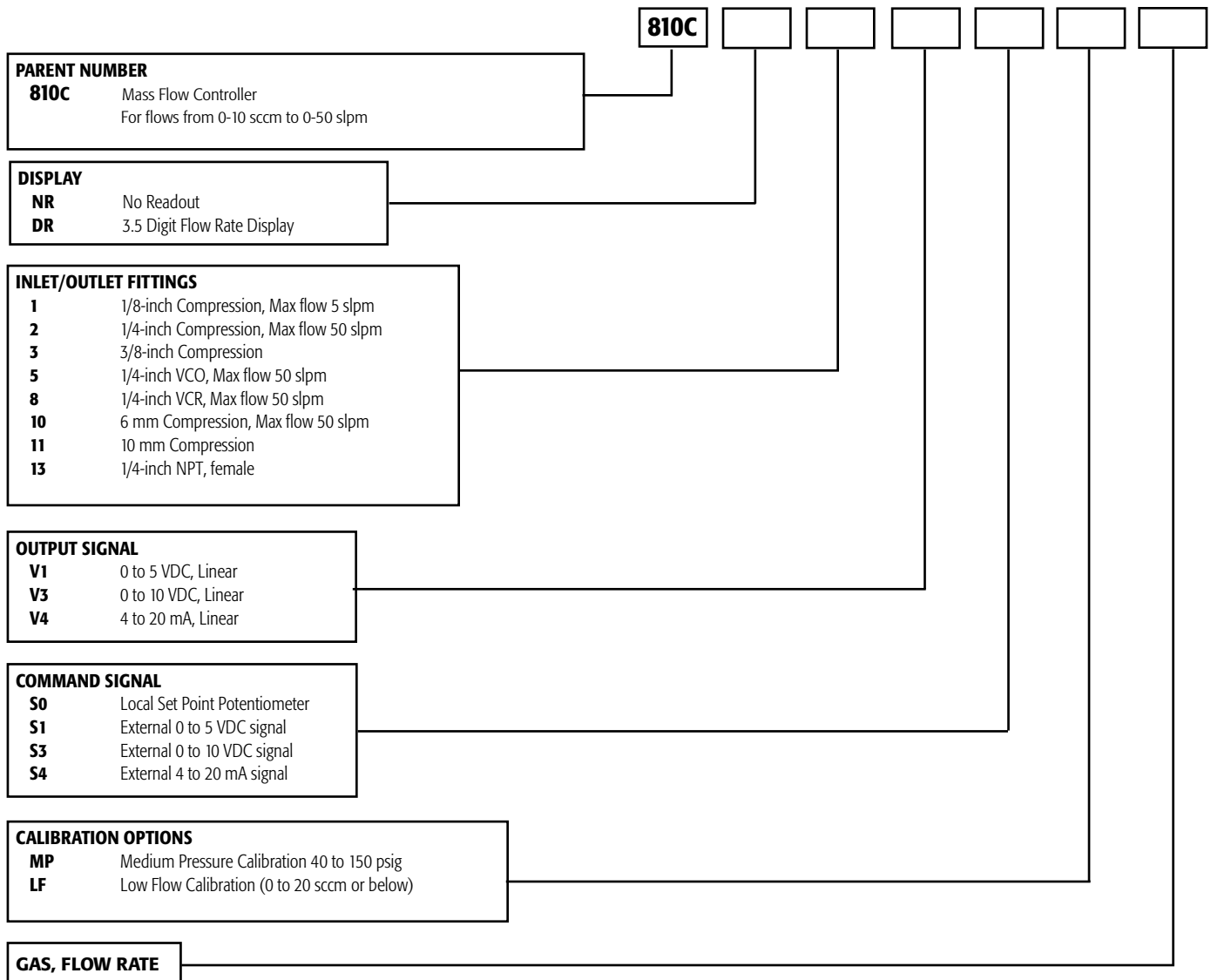

ACCESSORIES (Consult Factory)

CONNECTORS AND CABLES (Consult Factory)



q

SIERRA INSTRUMENTS, NORTH AMERICA • 5 Harris Court, Building L • Monterey, California • (800) 866-0200 • (831) 373-0200 • Fax (831) 373-4402 • www.sierrainstruments.com

SIERRA INSTRUMENTS, EUROPE • Bijlmansweid 2 • 1934RE Egmond aan den Hoef • The Netherlands • +31 72 5071400 • Fax: +31 72 5071401

SIERRA INSTRUMENTS, ASIA • Rm.618, Tomson Centre, Bldg. A • 188 Zhang Yang Road • Pu Dong New District • Shanghai, P.R. China 200122 • +8621 5879 8522 • Fax: +8621 5879 8586