

DIMENSIONS AND INSTALLATION

FLOWMETER LM SPFA VERSION + series

Please note that the SPFA replaces the SN, SP and SPVDF

These units are flowmeters having an integral electronics transmitting a pulse output linear to flow. The meters are rated to 40 bar pressure and 100°C. The main meter body and inlet and outlet pipes are made in 316 stainless steel. The rotor shaft is stainless steel with sapphire/sapphire bearings. The PFA (Teflon perfluoroalkoxy) rotor is equipped with 6 ferrites (sealed from the fluid) which are sensed by a coil mounted in the electronics housing. The standard O-ring material is FPM for the electronics/body seal. Other materials can be supplied so check the calibration certificate to confirm all materials. (The older SN version had a glass-filled nylon rotor, SP had a polypropylene rotor and the SPVDF had a PVDF rotor)

If it is necessary to remove the electronics then the line should be non-pressurised and drained down. The turbine ring assembly can then be simply pulled out. If it is held against the underside of the electronics and gently blown then the flowmeter action will be duplicated. (Ensure that any dangerous fluids that may be on the rotor assembly are removed before this test). On the ...FIN and ...HT and some other versions the electronics can be removed without breaking the liquid seal (see supplement).

The transmitter electronics has a 4-way M12 sensor connector [IEC-61076-2-101] rated to IP67 e.g. compatible with Brad Harrison, Hirschmann, ERNI, Murr and Turck Banner. The flowmeter is normally supplied with a separate 5m lead with the mating connector. The signal is an NPN open collector, 8 to 28Vdc input. *TTL and PNP are optional outputs.*

In Intrinsically Safe versions the electronics are protected by an IP65 die cast aluminium epoxy coated enclosure. The cap remains in situ and the box and sensor can be released using the 2 socket cap head screws on the inside of the electronics enclosure.

Installation

The LM series of flowmeters can accommodate poor installation conditions involving pipe bends, etc. The inlet tube is curved with a male ¼" BSP thread connection. It is desirable that valves or T-pieces are not mounted directly on to this inlet pipe, as a change in calibration from the factory calibration certificate will result. Some units have curved inlet and outlet pipes providing in-line piping and, optionally, flanges.

The transmitter should be installed in the horizontal plane with both the curve of the inlet tube and the electronics axis horizontal. On one face of the stainless steel body will be inscribed the word "TOP" which confirms the correct way up for the transmitter. There is also an arrow indicating the direction of flow. The inlet connection will be the curved pipe and will also be marked with an arrow. This installation attitude will duplicate that of the flowmeter's calibration test. If for any reason the inlet and outlet pipes are removed from the body, then it is essential that PTFE tape be placed on the pipe thread before re-assembly with the body. Care should be taken that small pieces of the tape do not shred and enter the flowmeter. Meters with curved inlet and outlet pipes will be welded and therefore are not removable.

The metering installation should avoid the following undesirable situations:

1. Two or more elbow bends or loops in different planes fitted prior to the flowmeter. This causes swirl in the pipe which can lead to errors. This can be corrected by separating the two bends by, if possible, 25 diameters and providing 25 diameters straight pipe after the second bend, which is immediately upstream of the flowmeter.
2. Partly closed valves should be avoided as these cause the flow across the pipe to travel at different velocities. This poor velocity profile can cause high or low readings.

For types 003, 005, 01, 05, 24, 45, and 48 which have an internal jet, care should be taken to ensure that they are seated firmly down if they have been removed for any reason.

If the installation is poor then it may be possible to effect an in-situ flow calibration at various flow rates to establish the effect on the flowmeter. If the operating flow range is small, a new "meter factor" of pulses per litre could be used optimised for the smaller range as a result of in-situ testing. Non-linearity over a wide flow range can be minimised using a microprocessor instrument having a linearising signal processing facility. In this case the display or flow rate signal will have an enhanced accuracy over and above the flowmeter performance.

Temperature

In higher temperature applications (above 40°C fluid temperature) **it is important that the electronics is not covered** and that there is a free flow of air around the electronics. In addition the electronics must be to the side of the meter and not above the flowmeter. This will avoid heat soak from the pipe. Lagging or insulation must not be used on the electronics. There is a supplemental note onHT versions that are rated to higher temperatures. This note includes revised installation drawings.

Viscosity Effects

Viscosity affects all turbine type meters. If the viscosity is low this is minimal. Viscosity imposes drag on the rotor reducing the RPM even at high flows. Rangeability (turndown) is also reduced and it is desirable to operate in the higher end of the meter flow range as non-linearity appears particularly at low flows.

A relatively high viscosity fluid can be metered if the flow rate is stable or of a limited range and if the application temperature and resulting viscosity of the fluid is also stable. This applies to many batching systems where simple recalibration will provide system accuracy.

All viscous fluids create an increased pressure drop throughout the pipe line systems. Since it is desirable to operate flowmeters at the higher end of their flow range, most users operate pumped rather than gravity fed systems for viscous fluids.

Possible sources of error – specific to low flow:

1. That small particles may be affecting/blocking the jet. The size of the jet hole is just 0.38mm for the 005 and 0.3mm for the 003. We recommend a 40 micron filter for the 005 and 003.
2. The installation must have the flowmeters inlet and outlet pipes in the horizontal plane. In addition, the electronics must also be in the horizontal plane. This ensures that the rotor axis is vertical and that there is minimum friction on the bearings. With higher friction, then at lower flows errors will be observed. In the worst case, the minimum flow measurable will be higher as well.
3. Air pockets within the flowmeter. When we calibrate on our flow rig, we are able to remove the air pockets by manipulating a flexible hose. This is necessary on all flowmeters below LM01 in size. Above this size then the simple throughput of water removes the air, but below this size then some assistance is required. Removing the air pocket can also be effected just by twisting the flowmeter along the axis of the pipe.
4. Vibrations in the pipe and flowmeter may cause extra pulses to occur but we would find this unusual. Clamping the meter may assist.

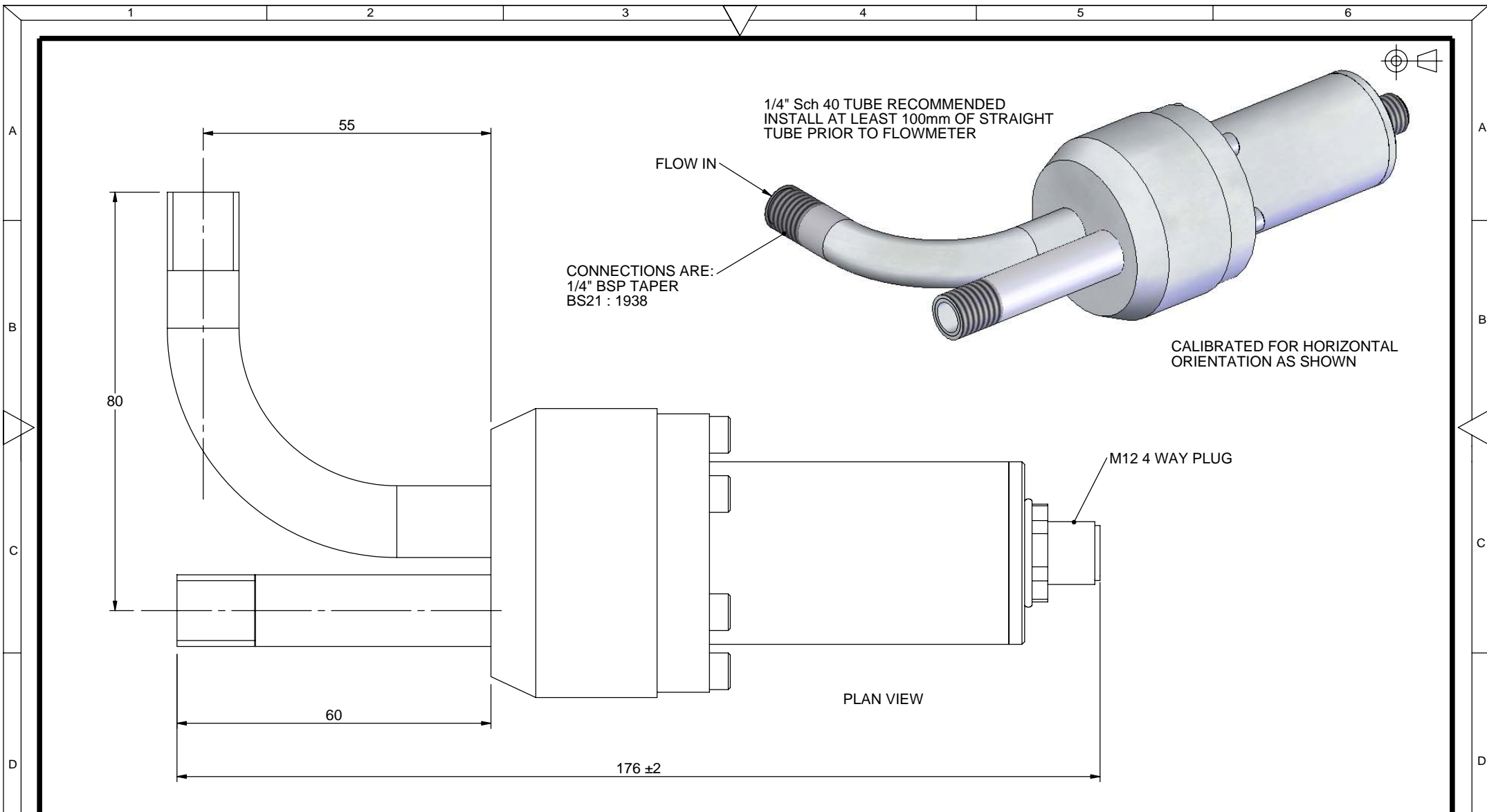

					FINISH 0.8µm Ra unless otherwise stated	MATERIAL:	Dimensions in mm unless otherwise stated	TOLERANCES	x. 1mm x.x 0.5mm	x.xx 0.25mm x.xxx 0.05mm	x° ¼°
					 LITRE METER Specialist flow measurement engineering Tel: 01296 420341 Fax: 01296 436446	Litre Meter Ltd 50/53 Rabans Close Rabans Lane Ind Est Aylesbury Bucks HP19 8TG	Title		Drawing No.		
1	2068	TRS		19.04.07			LM SN & SPFA 40 BAR FLOWMETER		C6077		
Issue	DCMR	Drawn	Appd	Date	Website http://www.litremeter.com	E-mail do@litremeter.com	STOCK CODE:		Copy No. <input type="text"/>		

IF IN DOUBT - ASK

REPORT ERRORS

DO NOT SCALE