



MilliGascounter MGC

## Features:

- Minimum flow rate **1 ml/day**
- Measuring resolution **1 milli-Ltr (mL)**  
Display resolution **1 micro-Ltr (µL)**
- Accuracy **±3 %**
- Use with inert and medium corrosive gases (biogas)
- Material: plexiglass (PMMA) / polycarbonate (PC)
- digital counter with programmed calibration factor
- battery operated; battery life-time 5-7 years
- low-maintenance

## Applications

The patented MilliGascounter<sup>®</sup> is designed for the measurement of small amounts of gas with ultra-low flow rates. It is suitable for measuring all inert and slightly aggressive gases, in particular those encountered in **biogas technology** or in **leak rate detection**.

## Measurement Principle

The gas to be measured flows through the gas inlet nozzle and up into the MilliGascounter (MGC) casing through a micro capillary tube. The MGC casing is filled with a packing liquid.

The gas rises as small bubbles through the packing liquid and collects in the measurement cell. The measurement cell lies fully within the packing liquid and tilts over an axle.

The measurement cell consists of two measuring chambers, which are filled alternatively by the rising gas bubbles. When a measuring chamber is full, the buoyancy of the filled chamber causes the measurement cell to tip over abruptly into such a position that the second

measuring chamber begins to fill and the first empties.

Through the combination of a permanent magnet and magnetic sensor (reed contact), this tilting procedure creates a pulse which is registered by a counter mechanism.

The measured gas escapes through the gas output nozzle.

## Measuring-Range

The minimum flow rate is theoretically 0 ltr/h, as there are no mechanical limitations on the MilliGascounter which would restrict the minimum flow.

However, at such micro flow rates, there are influences external to the MilliGascounter which become evident (tightness of the tube connection, permeability of the gas tubing). The **minimum flow rate** has therefore been defined as **1 ml/day**. The **maximum flow rate is 1.2 ltr/h**.

9

## Accuracy

Through a special manufacturing technique and high precision calibration, a **Measurement Accuracy of ±3%** has been achieved.

The volume is **measured** with a **resolution of 1 ml** and **displayed** with a **resolution of 1 micro-liter** in order to display the measured volume including the calibration factor.

## Gas Pressure & Temperature

The MGC has a **maximum gas inlet pressure of 50 mbar** (0.725 psi). The **minimum differential pressure is 3 mbar** (0.043 psi).

The MGC withstands constant use **temperatures ranging from +10 to +40 °C** (+50 to +104 °F).

## Data Presentation

The volume of the measured gas is displayed on an electronic counter / display located on the top of the MGC casing.

Additionally a reed contact (floating output) can be used as a signal output.

<sup>1</sup> Developed at the University of Applied Sciences Hamburg, Prof. Dr. Paul A. Scherer

## Dr.-Ing. Ritter Apparatebau GmbH

P.O. Box 70 04 56 • D-44884 Bochum • Germany  
Telephone: +49-234-280077 • Fax: +49-234-280078  
<http://www.ritter-app.com> • <http://www.milligascounter.de>  
Email: [mailbox@ritter-app.com](mailto:mailbox@ritter-app.com)

*Ritter Gas Meters  
... where Perfection becomes Reality*

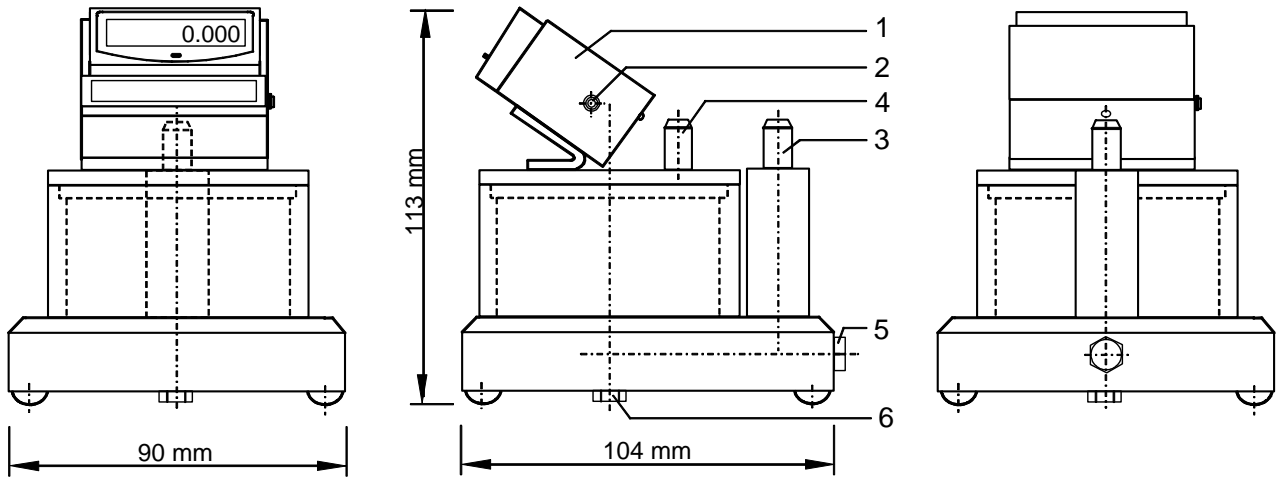

Front view

Side View

Rear View

- (1) Digital Display
- (2) Signal Output (reed contact)

- (3) Gas Inlet
- (4) Gas Outlet

- (5) Screw plug gas inlet channel
- (6) Screw plug micro capillary

### Performance Specifications

Minimum flow rate $Q_{\min}$	1	ml/day	<b>Maximum gas inlet pressure</b>	<b>50 mbar</b>
Maximum flow rate $Q_{\max}$	1.2	ltr/h	Minimum gas inlet pressure	5 mbar
Measuring accuracy	$\pm 3$	%	Gas inlet pressure at measurement start, approx. <sup>1)</sup>	8 mbar
Minimum indication / display resolution	0.001	ml	Connection gas in/outlet	nozzle
Packing liquid quantity, approx.	70	ml	Nozzle outside diameter	8 mm
Measuring Chamber volume	1	ml		

<sup>1)</sup> Higher gas inlet pressure until gas inlet channel and micro capillary in base plate are clear of packing liquid

### Material: Plexiglass (PMMA)

### Standard Equipment

Electronic counter / display	Gas inlet / outlet nozzles
Signal output (reed contact), floating output, 0.1 msec, maximum load 30 V DC / 0.33 A	Cleaning rod for micro capillary
2-chamber measurement cell	100 ml packing liquid
	1.5 m gas connection tubing (PVC)

### Accessories

Packing liquid 100 / 500 / 1,000 ml	Gas connection tubing (PVC)
-------------------------------------	-----------------------------

### Measurement principle with schematic:

The gas flows through the gas inlet nozzle (1) and up into the MGC casing through a micro capillary tube (2). The MGC casing is filled with a packing liquid (3).

The gas rises as small bubbles through the Packing Liquid and collects in the measurement cell (4).

The measurement cell consists of two measuring chambers (5), which are filled alternatively by the rising gas bubbles. When a measuring chamber is full, the buoyancy of the filled chamber causes the measurement cell to tip over abruptly into such a position that the second measuring chamber begins to fill and the first empties.

Through the combination of a permanent magnet (6) and magnetic sensor (reed contact) in the cover on top of the casing, this tilting procedure creates a pulse which is registered by the counter mechanism (8).

The measured gas escapes through the gas output nozzle (7).

The switching pulses of the reed contact can be obtained via the socket (9).

