

FlowPod Exd-Rated Flow Display

DESCRIPTION

The FlowPod is Litre Meter’s display unit, designed alongside the VFF Rotary Piston Flow Meter. The FlowPod comes in a compact and lightweight, flame-proof Stainless Steel enclosure that is only 85mm in diameter and weighs 1.6kg.

It is ideal for offshore and all Hazardous area applications and is supplied with one 316L Exd plug and one plastic plug.

TECHNICAL SPECIFICATIONS

Approvals		
ATEX Sira 15ATEX1190X	II 2 G D Ex db IIC T5	Ex tb IIIC 80 °C Tamb = -40°C to +75°C
IECEX SIR 15.0066X	Ex db IIC T5 Ex tb IIIC 80°C	Tamb = -40°C to +75°C
CSA CLASS 2258 02 PROCESS CONTROL EQUIPMENT For Hazardous Locations	Class I, Div 1, Groups B, C, D; Class II, Div 1, Groups E, F, G; Class III, Div 1	Ex d IIC T5 Gb Ex tb IIIC T80°C Db Tamb = -40°C to +75°C IP66/IP68 (2m)
CLASS 2258 82 PROCESS CONTROL EQUIPMENT For Hazardous Locations Certified to US Standards	Class I, Div 1, Groups B, C, D; Class II, Div 1, Groups E, F, G; Class III, Div 1	Class I, Zone 1, AEx d IIC T5 Gb Zone 21 AEx t IIIC T5 Db Tamb = -40°C to +75°C IP66/IP68 (2m)



Communication	Hart 7
Outputs	4-20mA Pulse out
Power	12 – 30 Vdc
Housing	316 Stainless Steel - IP66/68 Dual Certified

HIGH CONTRAST DISPLAY

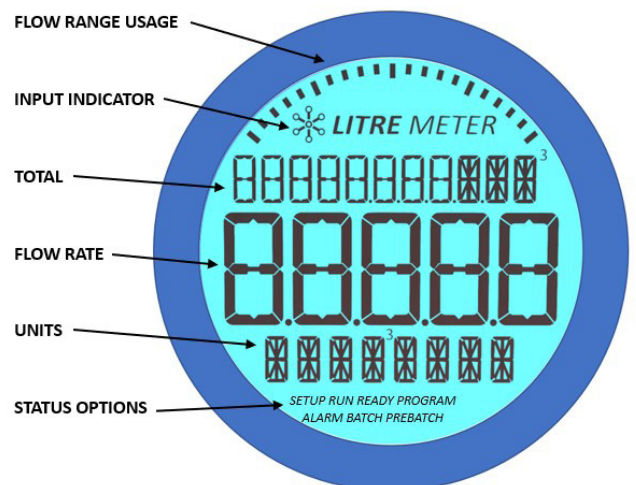

Features:

- Large flow rate indication and totalizer digits
- Memory card for quick programming and calibration
- Data logging capability
- Rotatable through 360° for optimised viewing angle
- Multiple measurement units
- 2 wire or 4 wire

FlowPod Exd-Rated Flow Display

OPTIONS AND CODING

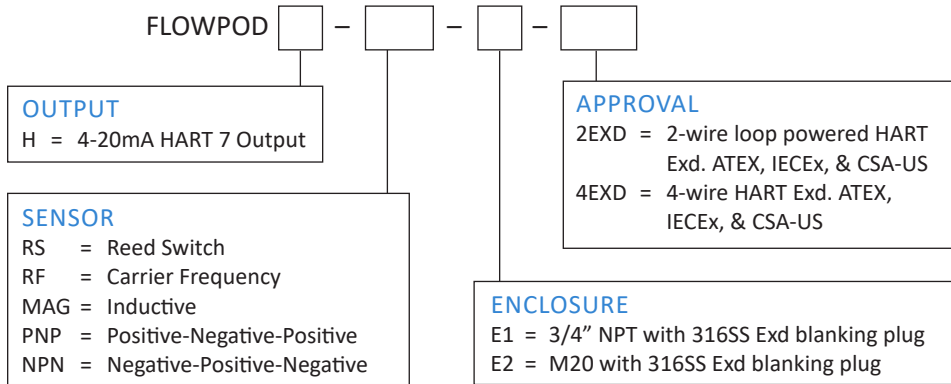

TERMINAL BOARD*

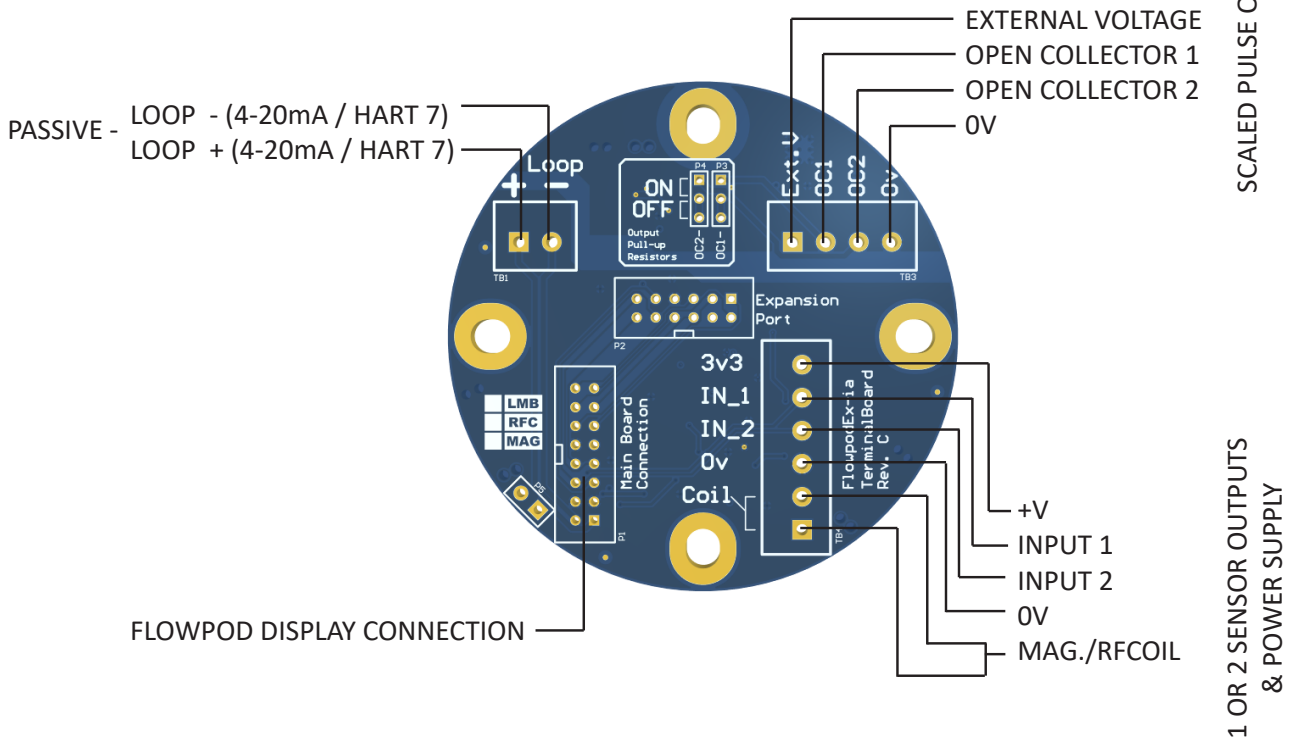

*For full wiring diagram please see user manual

Products may be subject to change without notice.
 Contact factory for the most up-to-date product information.

FlowPod Exd-Rated Flow Display

DIMENSIONS (mm)

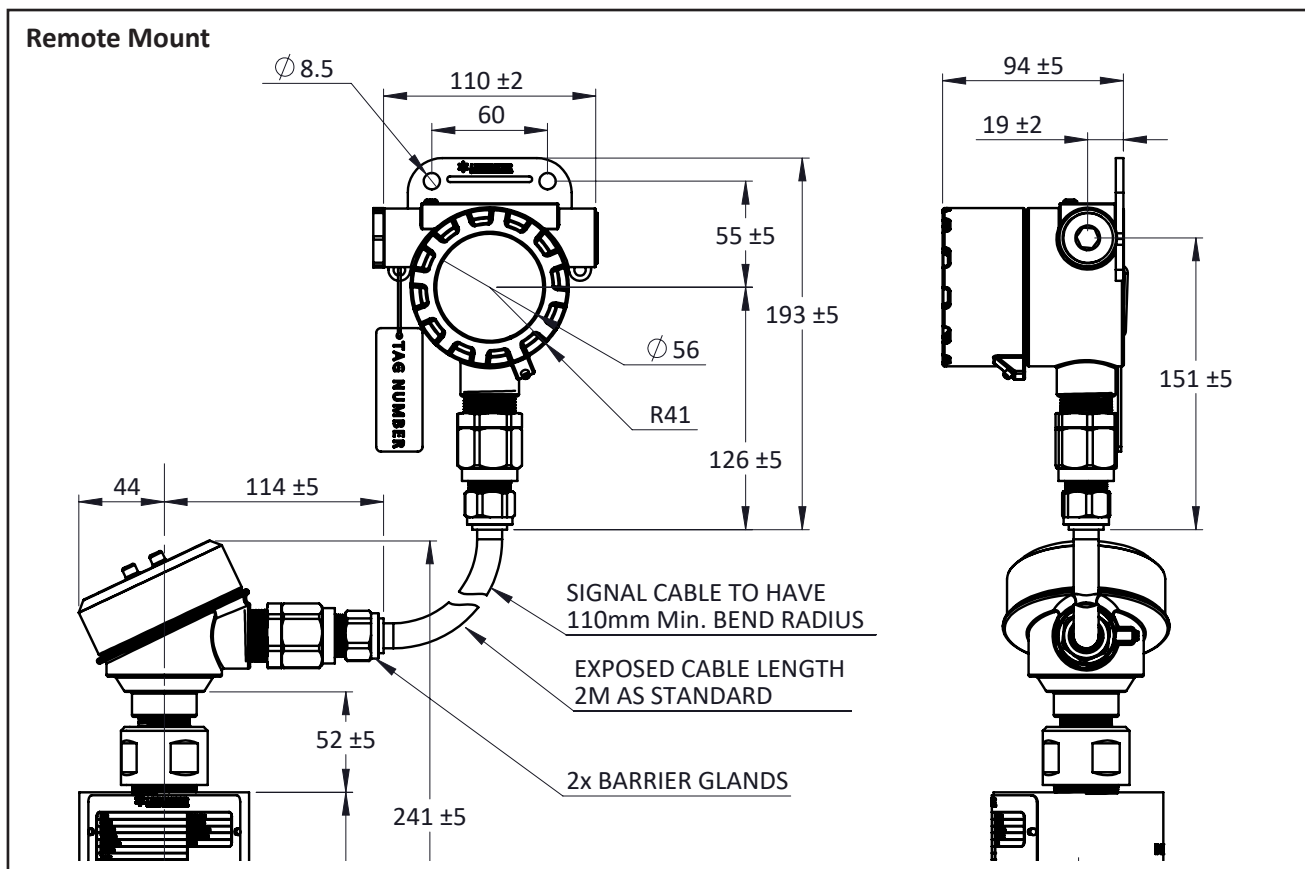
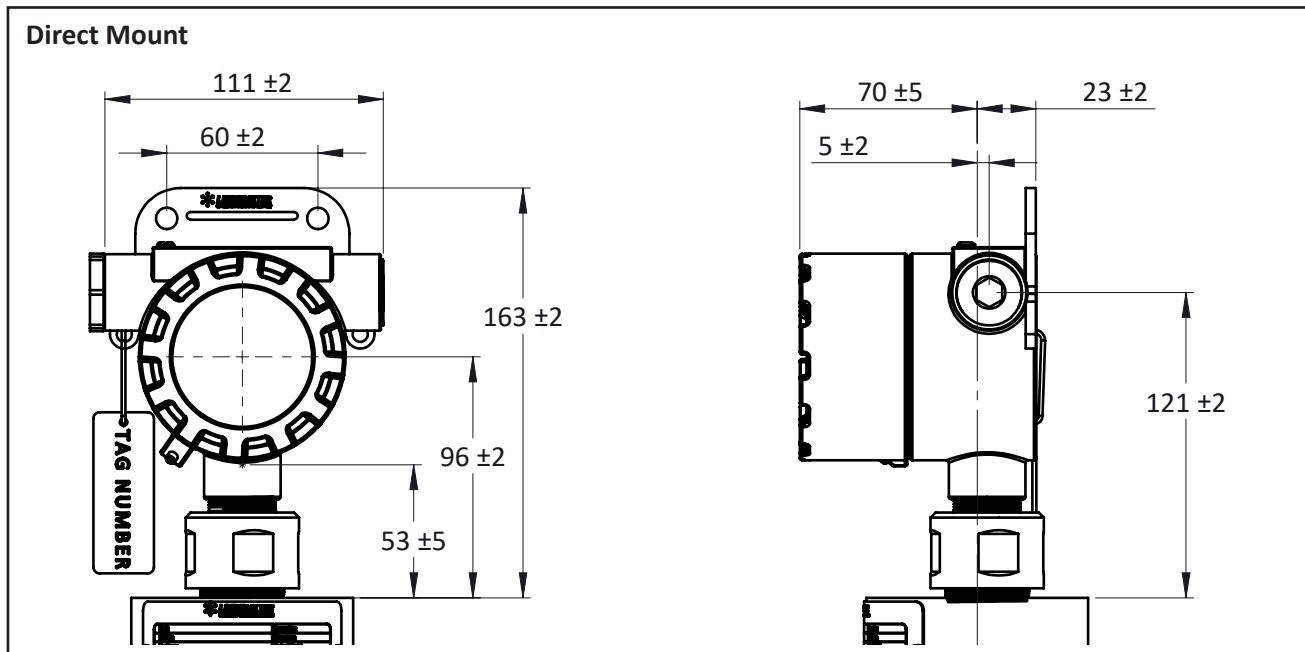

3D STEP Models are available upon request of factory.
Products may be subject to change without notice. Contact factory for the most up-to-date product information.